

EB

**Feature: Extremely low impedance downsize and high ripple current.
Suitable for main board.**

SPECIFICATIONS

Item	Performance Characteristics								
Category Temperature Range	-40 to +105°C								
Working Voltage Range	6.3 to 16Vdc								
Capacitance Range	470 to 3,300 μ F								
Capacitance Tolerance	$\pm 20\%$ (at 25°C 120Hz)								
Dissipation Factor (tan δ) (at 25°C 120Hz)	<table border="1"> <thead> <tr> <th>Rated Voltage (V)</th> <th>6.3</th> <th>10</th> <th>16</th> </tr> </thead> <tbody> <tr> <td>tan δ (Max)</td> <td>0.15</td> <td>0.14</td> <td>0.12</td> </tr> </tbody> </table> <p>The above values should be increased by 0.02 for every additional 1000 μ F</p>	Rated Voltage (V)	6.3	10	16	tan δ (Max)	0.15	0.14	0.12
Rated Voltage (V)	6.3	10	16						
tan δ (Max)	0.15	0.14	0.12						
Leakage Current	<p>$I = 0.03CV$ or $3 \mu A$, whichever is greater</p> <p>I: Leakage current. (μA) C:Rated capacitance. (μF) V: Rated voltage. (V) The rated voltage is impressed for two minutes.</p>								
Endurance	<p>After applying rated voltage to the capacitor for 2,000 hours at 105°C (1,000 hours \cong 6.3 ϕ) the following characteristics shall be satisfied when the capacitor has been restored to 25°C.</p> <p>Capacitance change $\cong \pm 25\%$ of the initial value Dissipation factor (tan δ) $\cong 200\%$ of the specified value Leakage current \cong specified value</p>								
Shelf Life	<p>After exposing the capacitor for 500 hours at 105°C, without applying voltage, the following characteristics shall be satisfied when the capacitor has been restored to 25°C.</p> <p>Capacitance change $\cong \pm 25\%$ of the initial value Dissipation factor (tan δ) $\cong 200\%$ of the specified value Leakage current $\cong 200\%$ of the specified value</p>								
Others	Conforms to JIS C-5141 (1991), characteristic W								

RIPPLE CURRENT MULTIPLIERS

Temperature Multipliers

Temp (°C)	40	60	70	85	95	105
Factor	2.10	1.90	1.65	1.40	1.25	1.00

Frequency Multipliers

Freq.(Hz)	60	120	1K	10K	100K
Vdc					
6.3 to 16	0.60	0.75	0.90	0.98	1.00

DIMENSIONS(mm)

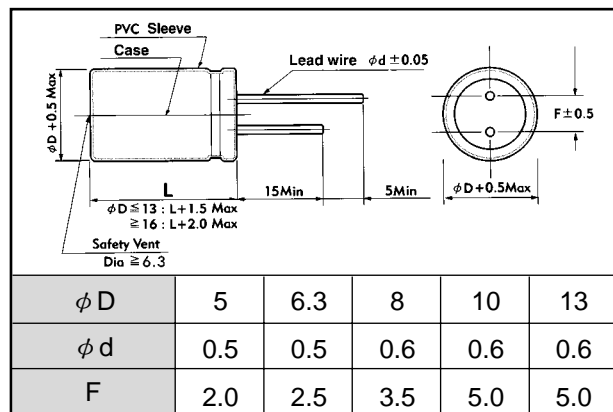

EB
Case size & Permissible Ripple Current

Nominal Capacitance (μ F)	6.3 V			10 V			16 V		
	Case Size	Max. Impedance @ 25°C 100kHz (Ω)	Max. Ripple Current @ 105°C 100kHz (mA rms)	Case Size	Max. Impedance @ 25°C 100kHz (Ω)	Max. Ripple Current @ 105°C 100kHz (mA rms)	Case Size	Max. Impedance @ 25°C 100kHz (Ω)	Max. Ripple Current @ 105°C 100kHz (mA rms)
	ϕ DxL (mm)			ϕ DxL (mm)			ϕ DxL (mm)		
82	5x11	1.85	165	5x11	1.35	200	6.3x11	1.20	250
100	5x11	1.65	180	5x11	1.18	260	6.3x11	0.98	300
150	6.3x11	1.32	215	6.3x11	0.96	340	6.3x11	0.88	350
220	6.3x11	0.68	295	6.3x11	0.48	425	8x12	0.42	430
330	6.3x11	0.32	425	8x12	0.25	525	8x12	0.18	795
470	8x12	0.078	605	8x12	0.052	805	8x12	0.036	1140
680	8x12	0.052	805	8x12	0.036	1140	8x16	0.028	1490
							10x12	0.026	1540
820	8x16	0.036	1140	8x16	0.033	1200	10x16	0.024	1605
1000	8x16	0.032	1210	8x16	0.028	1490	8x20	0.019	1870
				10x12	0.026	1540	10x16	0.019	2000
1200	8x16	0.028	1490	10x16	0.024	1605	10x20	0.017	2110
1500	8x20	0.016	1870	8x20	0.019	1870	10x20	0.013	2550
	10x12	0.026	1540	10x16	0.019	2000			
1800	8x20	0.021	1870	10x20	0.013	2550	10x25	0.012	2800
	10x16	0.019	2000						
2200	10x20	0.013	2550	10x25	0.012	2800	10x25	0.012	2950
3300	10x25	0.012	2800	10x25	0.012	2950	13x25	0.012	3050