

EL

**Feature: Extremely low impedance downsize and high ripple current.
Suitable for main board.**

SPECIFICATIONS

Item	Performance Characteristics														
Category Temperature Range	-40 to +105°C														
Working Voltage Range	6.3 to 50Vdc														
Capacitance Range	56 to 6,800 μ F														
Capacitance Tolerance	$\pm 20\%$ (at 25°C 120Hz)														
Dissipation Factor (tan δ) (at 25°C 120Hz)	<table border="1"> <thead> <tr> <th>Rated Voltage (V)</th> <th>6.3</th> <th>10</th> <th>16</th> <th>25</th> <th>35</th> <th>50</th> </tr> </thead> <tbody> <tr> <td>tan δ (Max)</td> <td>0.22</td> <td>0.19</td> <td>0.16</td> <td>0.14</td> <td>0.12</td> <td>0.10</td> </tr> </tbody> </table> <p>The above values should be increased by 0.02 for every additional 1000 μ F</p>	Rated Voltage (V)	6.3	10	16	25	35	50	tan δ (Max)	0.22	0.19	0.16	0.14	0.12	0.10
Rated Voltage (V)	6.3	10	16	25	35	50									
tan δ (Max)	0.22	0.19	0.16	0.14	0.12	0.10									
Leakage Current	$I = 0.01CV$ or $3 \mu A$, whichever is greater I: Leakage current. (μA) C: Rated capacitance. (μF) V: Rated voltage. (V) The rated voltage is impressed for two minutes.														
Endurance	After applying rated voltage to the capacitor for 2,000 hours at 105°C, the following characteristics shall be satisfied when the capacitor has been restored to 25°C. <table border="0"> <tr> <td>Capacitance change</td> <td>$\leq \pm 25\%$ of the initial value</td> </tr> <tr> <td>Dissipation factor (tan δ)</td> <td>$\leq 200\%$ of the specified value</td> </tr> <tr> <td>Leakage current</td> <td>\leq specified value</td> </tr> </table>	Capacitance change	$\leq \pm 25\%$ of the initial value	Dissipation factor (tan δ)	$\leq 200\%$ of the specified value	Leakage current	\leq specified value								
Capacitance change	$\leq \pm 25\%$ of the initial value														
Dissipation factor (tan δ)	$\leq 200\%$ of the specified value														
Leakage current	\leq specified value														
Shelf Life	After exposing the capacitor for 500 hours at 105°C, without applying voltage, the following characteristics shall be satisfied when the capacitor has been restored to 25°C. <table border="0"> <tr> <td>Capacitance change</td> <td>$\leq \pm 25\%$ of the initial value</td> </tr> <tr> <td>Dissipation factor (tan δ)</td> <td>$\leq 200\%$ of the specified value</td> </tr> <tr> <td>Leakage current</td> <td>$\leq 200\%$ of the specified value</td> </tr> </table>	Capacitance change	$\leq \pm 25\%$ of the initial value	Dissipation factor (tan δ)	$\leq 200\%$ of the specified value	Leakage current	$\leq 200\%$ of the specified value								
Capacitance change	$\leq \pm 25\%$ of the initial value														
Dissipation factor (tan δ)	$\leq 200\%$ of the specified value														
Leakage current	$\leq 200\%$ of the specified value														
Others	Conforms to JIS C-5141 (1991), characteristic W														

RIPPLE CURRENT MULTIPLIERS

Temperature Multipliers

Temp (°C)	40	60	70	85	95	105
Factor	2.10	1.90	1.65	1.40	1.25	1.00

Frequency Multipliers

Freq.(Hz)	50(60)	120	1K	10K	100K
6.3 to 16	0.60	0.75	0.90	0.98	1.00
25 to 50	0.50	0.62	0.85	0.95	1.00

DIMENSIONS(mm)

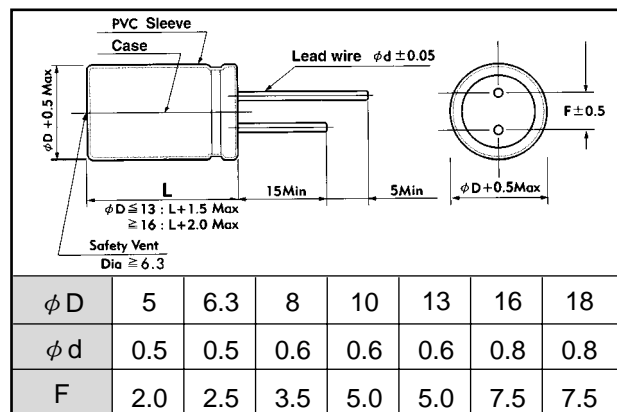

EL
Case size & Permissible Ripple Current

Nominal Capacitance (μ F)	6.3 V				10 V				16 V			
	Case Size ϕ DxL (mm)	Max. Impedance		Max. Ripple Current @ 105°C 100kHz (mA rms)	Case Size ϕ DxL (mm)	Max. Impedance		Max. Ripple Current @ 105°C 100kHz (mA rms)	Case Size ϕ DxL (mm)	Max. Impedance		Max. Ripple Current @ 105°C 100kHz (mA rms)
		@25°C 100kHz (Ω)	@-10°C 100kHz (Ω)			@25°C 100kHz (Ω)	@-10°C 100kHz (Ω)			@25°C 100kHz (Ω)	@-10°C 100kHz (Ω)	
100	5x11	1.78	2.69	175	5x11	1.48	2.48	250	6.3x11	1.28	2.16	290
220	6.3x11	0.88	1.76	280	6.3x11	0.58	1.66	405	8x12	0.46	1.56	410
330	6.3x11	0.45	1.32	405	8x12	0.38	1.28	500	8x12	0.28	1.08	760
470	8x12	0.11	0.38	560	8x12	0.072	0.22	760	8x16	0.056	0.17	995
560	8x12	0.072	0.22	760	8x16	0.069	0.20	805	8x20	0.052	0.16	1050
680	8x12	0.068	0.21	800	8x16	0.056	0.17	995	10x16	0.038	0.12	1430
820	8x16	0.056	0.17	995	8x20	0.052	0.16	1050	10x20	0.035	0.11	1520
1000	8x16	0.053	0.16	1030	8x20	0.041	0.13	1250	10x20	0.023	0.069	1820
1200	8x20	0.041	0.13	1250	10x20	0.023	0.069	1820	10x25	0.022	0.066	2150
1500	10x20	0.023	0.069	1820	10x25	0.022	0.066	2150	13x20	0.021	0.053	2360
2200	10x25	0.022	0.066	2150	13x20	0.021	0.053	2360	13x25	0.018	0.045	2770
2700	10x30	0.022	0.066	2200	13x20	0.021	0.053	2395	13x30	0.016	0.041	3290
3300	13x20	0.021	0.053	2360	13x25	0.018	0.045	2770	13x35	0.015	0.039	3400
3900	13x25	0.018	0.045	2770	13x30	0.016	0.041	3290	16x25	0.016	0.043	3460
4700	13x30	0.016	0.041	3290	13x35	0.015	0.039	3400	16x32	0.016	0.043	3500
5600	13x35	0.015	0.039	3400	13x40	0.016	0.043	3460	16x36	0.015	0.042	3540
6800	13x40	0.016	0.043	3460	16x32	0.017	0.040	3500	16x40	0.015	0.040	3585

Nominal Capacitance (μ F)	25 V				35 V				50 V			
	Case Size ϕ DxL (mm)	Max. Impedance		Max. Ripple Current @ 105°C 100kHz (mA rms)	Case Size ϕ DxL (mm)	Max. Impedance		Max. Ripple Current @ 105°C 100kHz (mA rms)	Case Size ϕ DxL (mm)	Max. Impedance		Max. Ripple Current @ 105°C 100kHz (mA rms)
		@25°C 100kHz (Ω)	@-10°C 100kHz (Ω)			@25°C 100kHz (Ω)	@-10°C 100kHz (Ω)			@25°C 100kHz (Ω)	@-10°C 100kHz (Ω)	
56	6.3x11	0.88	0.90	270	6.3x11	0.76	1.24	405	8x12	0.64	1.40	385
68	6.3x11	0.66	0.85	290	8x12	0.56	0.76	430	8x12	0.48	0.90	405
100	6.3x11	0.43	0.50	405	8x12	0.38	0.56	450	8x12	0.22	0.63	724
150	8x12	0.12	0.40	415	8x12	0.072	0.22	760	8x16	0.061	0.18	979
220	8x12	0.072	0.22	760	8x16	0.056	0.17	995	10x16	0.042	0.12	1370
330	8x16	0.056	0.17	995	10x16	0.038	0.12	1430	10x25	0.028	0.085	1870
470	10x16	0.038	0.12	1430	10x20	0.023	0.069	1820	13x20	0.027	0.068	2050
560	10x20	0.035	0.11	1505	10x25	0.022	0.066	2150	13x25	0.023	0.059	2410
680	10x20	0.023	0.069	1820	13x20	0.021	0.053	2360	13x30	0.021	0.052	2860
820	10x25	0.022	0.066	2150	13x20	0.020	0.052	2410	13x35	0.019	0.051	2960
1000	13x20	0.021	0.053	2360	13x25	0.018	0.045	2770	16x25	0.021	0.056	3010
1200	13x25	0.021	0.053	2400	13x30	0.016	0.041	3290				
1500	13x25	0.018	0.045	2770	13x35	0.015	0.039	3400				
2200	13x35	0.015	0.039	3400	16x32	0.015	0.039	3500				
2700	16x25	0.016	0.043	3460								